

## High-Density Scanner/Multiplexer

- ◆ **User Configurable as Any of the Following Combinations:**

- One 1x96 multiplexer, 2-wire
- Two 1x48 multiplexers, 2-wire
- Four 1x24 multiplexers, 2-wire
- Eight 1x12 multiplexers, 2-wire
- Sixteen 1x6 multiplexers, 2-wire
- One 1x48 multiplexer, 4-wire
- Two 1x24 multiplexers, 4-wire
- Four 1x12 multiplexers, 4-wire
- Eight 1x6 multiplexers, 4-wire
- One 1x192 multiplexer, 1-wire

- ◆ **50MHz Bandwidth**

- ◆ **Low Thermal Offset**

Racal Instruments 1260-35 is a high-density scanner or multiplexer, ideal for applications with large switch requirements such as continuity testing, and audio or telephone line switching.

The 1260-35 can be user-configured in many ways, from a 1x96 two-wire to sixteen 1x6 two-wire multiplexers, switching up to 250 VDC and 1A per channel. An additional relay that selects between the high and low sides of the two-wire mode allows the 1260-35 to act as a 1x192 1-wire scanner.

The 1260-35A is supplied with crimp pin type user connectors, and the 1260-35 with ribbon cable type mating connectors.

Relay coil current monitoring is available to provide confidence checking which gives the user assurance of proper relay operation.

The 1260-35 is controlled by the Option 01 message-based interface.

# 1260-35 PRODUCT SPECIFICATIONS

## Maximum Switchable Voltage

(Terminal-Terminal or Terminal-Chassis)  
250 VDC or VACrms

## Maximum Switchable Current

Per Channel: 1A

## Maximum Switchable Power

Per Channel: 30WDC, 62.5 VAC

## DC PERFORMANCE

### Path Resistance

<1.0Ω (1x96 configuration)

<0.5Ω (1x6 configuration)

### Isolation

>7.5 x 10<sup>8</sup> Ω

## AC PERFORMANCE (into 50Ω)

### Capacitance

Open Channel: <600 pF

(1x96 configuration)

Channel-Chassis: <200 pF

(1x96 configuration)

High-Low: <600 pF

(1x96 configuration)

### Bandwidth(-3dB)

>15 MHz (1x48 configuration)

>50 MHz (1x6 configuration)

### Insertion Loss

100kHz: < 0.1 dB (1x6 configuration)

1MHz: < 0.5 dB (1x6 configuration)

10MHz: < 1.0 dB (1x6 configuration)

### Crosstalk

100kHz: <-90 dB

1MHz: <-70 dB

## VXIBUS INTERFACE DATA

### Cooling Requirements

Airflow: 4.0 liters/Sec

Back Pressure: 0.5 mm H<sub>2</sub>O

### Power Requirements (I<sub>pm</sub>)

+5V: 0.4A (2.8A with Option 01 installed)

+24V: 10 mA per relay (energized)

### Dimensions

C-size, Single-slot VXIbus Module

### Weight

3.07 lb. (1.33 kg) without Option 01

3.35 lb. (1.51 kg) with Option 01

### Typical Programming Syntax

Programming Syntax is in the form:

"<module address >.<channel>"

Example: CLOSE 3.02

This CLOSE statement will close channel number 2 on the 1260-35 module at card address 3.

*Note:* Module is supplied with one set of mating connectors. Additional connectors can be ordered using the part number shown below. This module has two options: IDC (ribbon cable) or Crimp (discrete wire connectors).

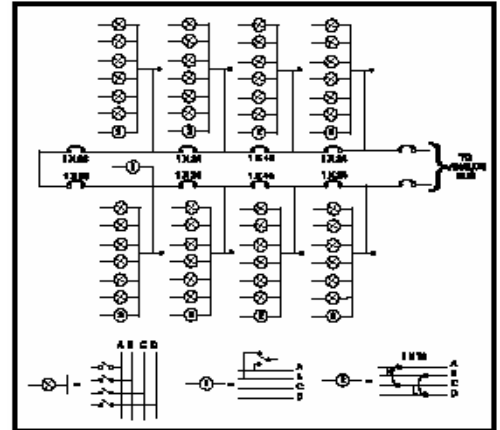

Model 1260-35  
96 two-wire channels configured as sixteen 1x6 multiplexers.

## ORDERING INFORMATION

### MODEL/DESCRIPTION

Racal Instruments 1260-35, 2-Wire, 1x96 Multiplexer with IDC connectors  
Racal Instruments 1260-35A 2-Wire, 1x96 Multiplexer with crimp connectors  
Option 01\*, Smart Card Module (installed)  
64-pin Din Connector IDC (4 supplied)  
64-pin Din Connector Crimp Body (4 supplied with -A)  
64-pin Din Connector Crimp Pin (256 supplied with -A)  
Crimp Tool for 602159-900  
Insertion Tool for 602159-900  
Extraction Tool for 602159-900

\*One Option 01 must be ordered with switch system. Please specify the card on which Option 01 will be installed

### PART NUMBER

404944  
404944-001  
OPT-401901-005  
602004  
602159-064  
602159-900  
990897  
990898  
990899

The EADS North America Defense Test and Services policy is one of continuous development, consequently the equipment may vary in detail from the description and specification in this publication.



EADS North America Defense Test and Services  
1.800.722.2528/1.949.859.8999 sales@eads-nadefense.com